

T16000

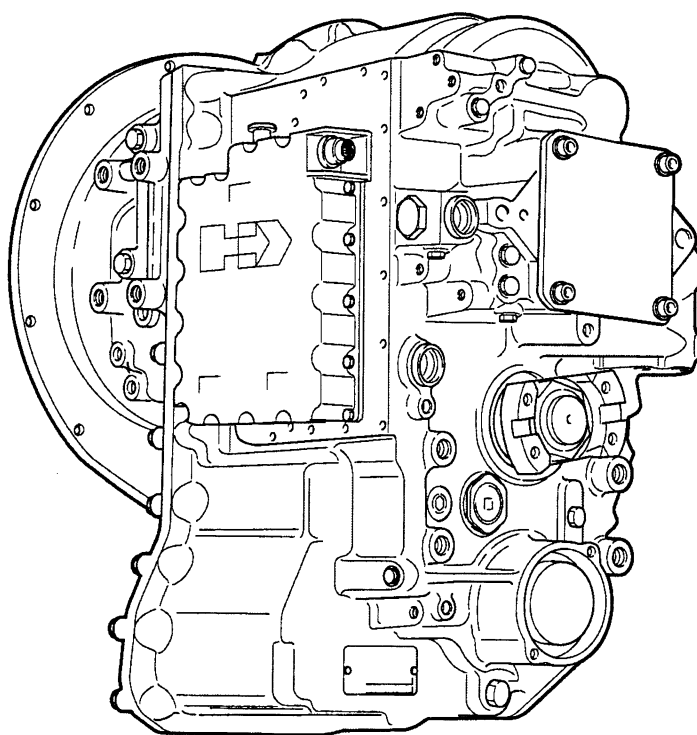

Date : 07-JUL-03
Revised :
MODEL : 4262467

1217FT16000-23
ASSY-T16000 TRANSMISSION FOR NEW HOLLAND ITALIA

<u>Item</u>	<u>Qty</u>	<u>Part Number</u>	<u>%</u>	<u>Description</u>
-------------	------------	--------------------	----------	--------------------

N.S.S. - Not Sold Separately
N.I. - Not Illustrated
% - Part Stock Recommendation

T16000

CONVERTER HOUSING GROUP

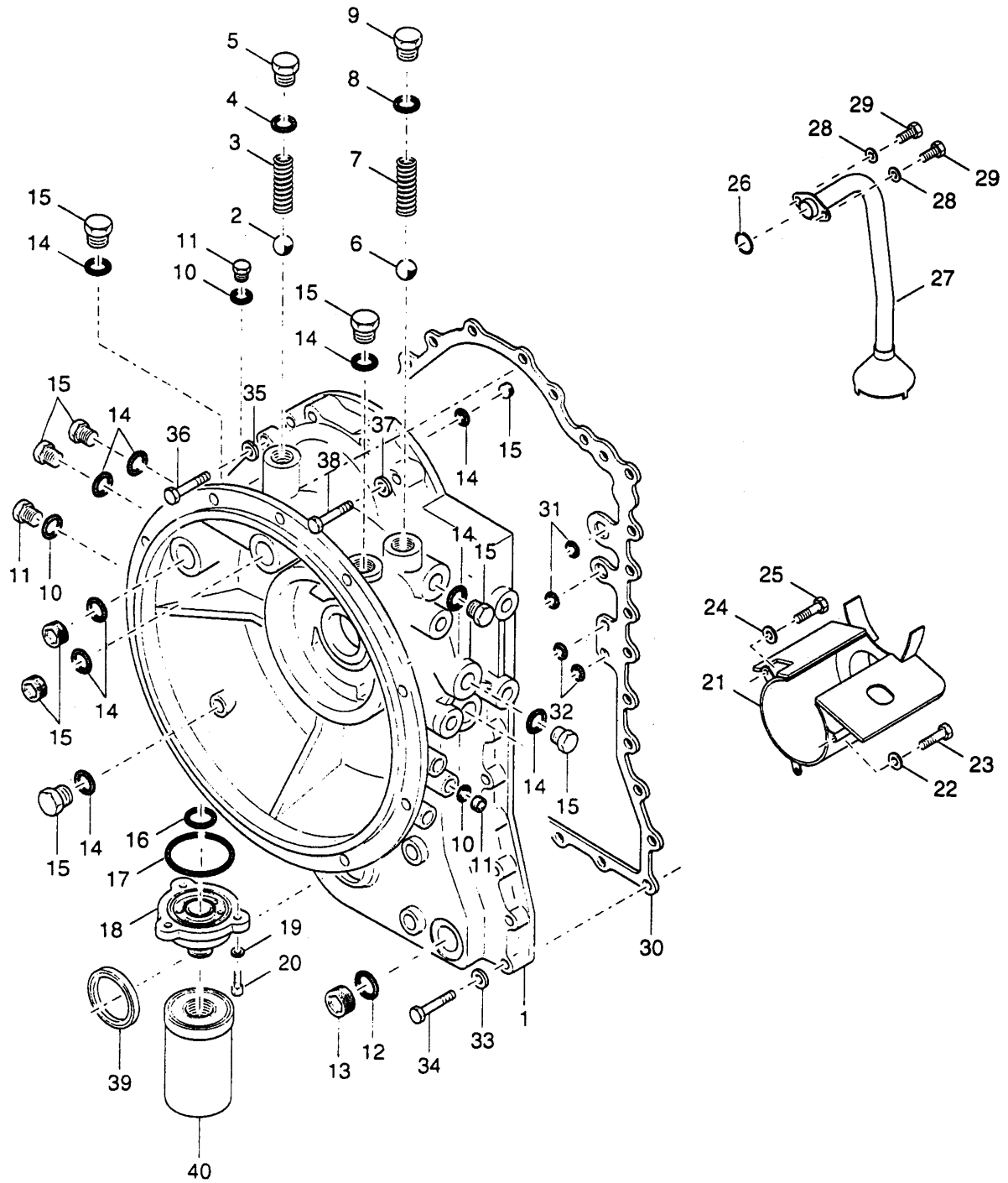

Date : 07-JUL-03
Revised : G
MODEL : 4500702

T16000
GROUP-CONVERTER HOUSING

<u>Item</u>	<u>Qty</u>	<u>Part Number</u>	<u>%</u>	<u>Description</u>
1	1	4203970	E	ASSY CONVERTER HOUSING AND EXPANTION PLUGS
2	1	10J24		BALL
3	1	4204243		SPRING BY-PASS
4	1	76K119	B	O RING - PART OF ITEM 5
5	1	4204244		PLUG BY-PASS - INCLUDING ITEM 4
6	1	19JM250		BALL
7	1	4203857		SPRING-SAFETY VALVE
8	1	76K123	B	O-RING - PART OF ITEM 9
9	1	4203848		PLUG M33X2 - INCLUDING ITEM 8
10	3	76K11	B	O RING - PART OF ITEM 11
11	3	4203846		PLUG M10X1 - INCLUDING ITEM 10
12				Not Used On This Model
13				Not Used On This Model
14	8	76K116	B	O-RING - PART OF ITEM 15
15	8	4203847		PLUG M22X1,5 - INCLUDING ITEM 16
16	1	4204245	B	O-RING FILTER ADAPTER
17	1	25K30228	B	O-RING
18	1	4205241		ADAPTOR-FILTER
19	3	6EM100		LOCKWASHER
20	3	1GM1025		SCREW
21	1	4204313		OIL-BAFFLE
22	2	6EM100		LOCKWASHER
23	2	1GM1016		CAPSCREW
24	1	6EM100		LOCKWASHER
25	1	1CM1016		CAPSCREW

N.S.S. - Not Sold Separately
N.I. - Not Illustrated
% - Part Stock Recommendation

Date : 07-JUL-03
Revised : G
MODEL : 4500702

T16000
GROUP-CONVERTER HOUSING

<u>Item</u>	<u>Qty</u>	<u>Part Number</u>	<u>%</u>	<u>Description</u>
26	1	76K218	B	"O" RING-SUCTION TUBE
27	1	4204237		ASSY SUCTION TUBE
28	2	6EM100		LOCKWASHER
29	2	1GM1016		SCREW
30	1	4203901	B	GASKET-CONV HSG TO TRANS CASE
31	2	60K20028	B	O RING
32	2	76K13	B	"O"-RING
33	14	6EM100		LOCKWASHER
34	14	7CM1050		SCREW
35	2	6EM100		LOCKWASHER
36	1	7CM1030		CAPSCREW
36A	1	3GM1030		SCREW
37	4	6EM100		LOCKWASHER
38	4	7CM1080		SCREW
39	1	4203860	B	OIL SEAL
40	1	4203691	D	ASSEMBLY - FILTER

N.S.S. - Not Sold Separately
N.I. - Not Illustrated
% - Part Stock Recommendation

T16000

TRANSMISSION CASE GROUP

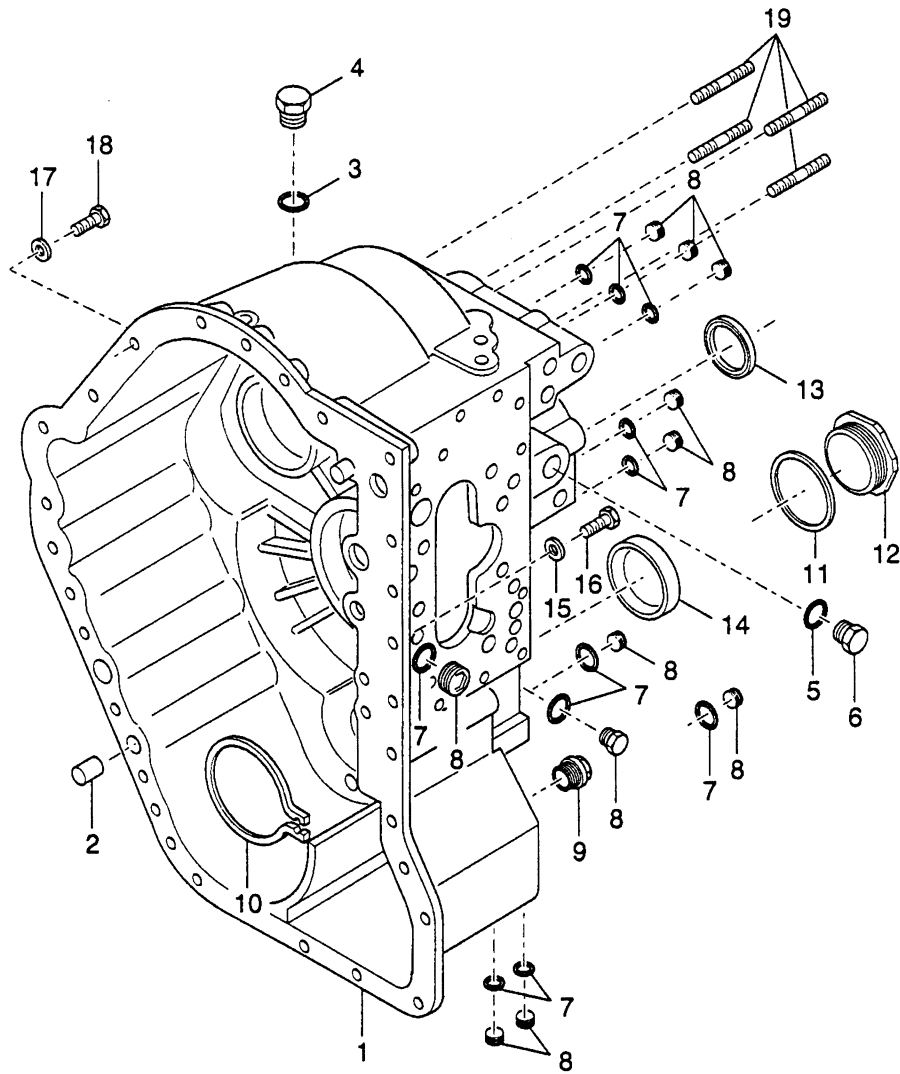

Date : 07-JUL-03
Revised : B
MODEL : 4500708

T16000
GROUP-TRANSMISSION CASE

<u>Item</u>	<u>Qty</u>	<u>Part Number</u>	<u>%</u>	<u>Description</u>
1	1	4204281	E	ASSY TRANSMISSION CASE AND PLUG
2	2	4203907		PIN-DOWEL
3	1	76K116	B	O-RING - PART OF ITEM 4
4	1	4203847		PLUG M22X1,5 - INCLUDING ITEM 3
5	1	76K210	B	O RING - PART OF ITEM 6
6	1	4203849		PLUG 1.0625-12 UN - INCLUDING ITEM 5
7	11	76K11	B	O RING - PART OF ITEM 8
8	11	4203846		PLUG M10X1 - INCLUDING ITEM 7
9	1	4203567		PLUG-MAGNETIC DRAIN
10	1	234229	C	SNAP RING EXTERNAL-SPECIAL
11	1	219373	B	GASKET
12	1	4204249		PLUG
13	1	4203860	B	OIL SEAL
14	1	4204250		END PLUG
15	5	6EM100		LOCKWASHER
16A	2	7CM1035		CAPSCREW
16	3	7CM1030		CAPSCREW
17	4	6EM100		LOCKWASHER
18	4	7CM1030		CAPSCREW
19	4	4204248		STUD M12-1/2

N.S.S. - Not Sold Separately
N.I. - Not Illustrated
% - Part Stock Recommendation

T16000
TORQUE CONVERTER GROUP

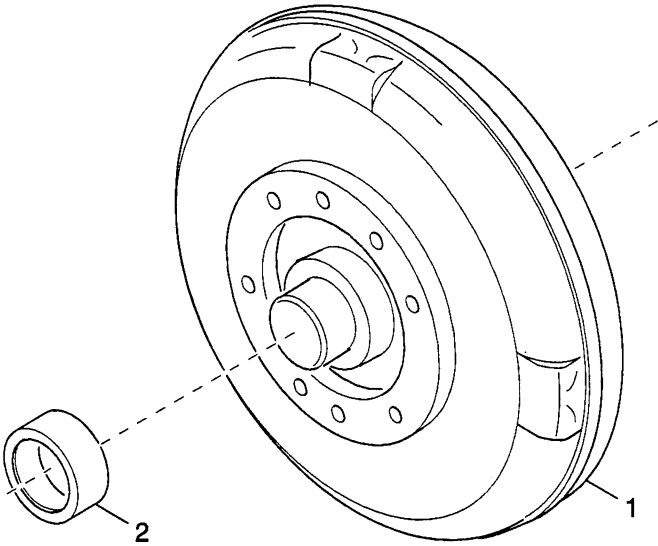

Date : 07-JUL-03
Revised :
MODEL : 4503098

T16000
GROUP-TORQUE CONVERTER

<u>Item</u>	<u>Qty</u>	<u>Part Number</u>	<u>%</u>	<u>Description</u>
1	1	4209022	E	ASSY-TORQUE CONV & BUSHING-INCLUDING ITEM 2
2	1	4208824		BUSHING-CONVERTER PILOT - PART OF ITEM 1

N.S.S. - Not Sold Separately
N.I. - Not Illustrated
% - Part Stock Recommendation

T16000
PUMP DRIVE GROUP

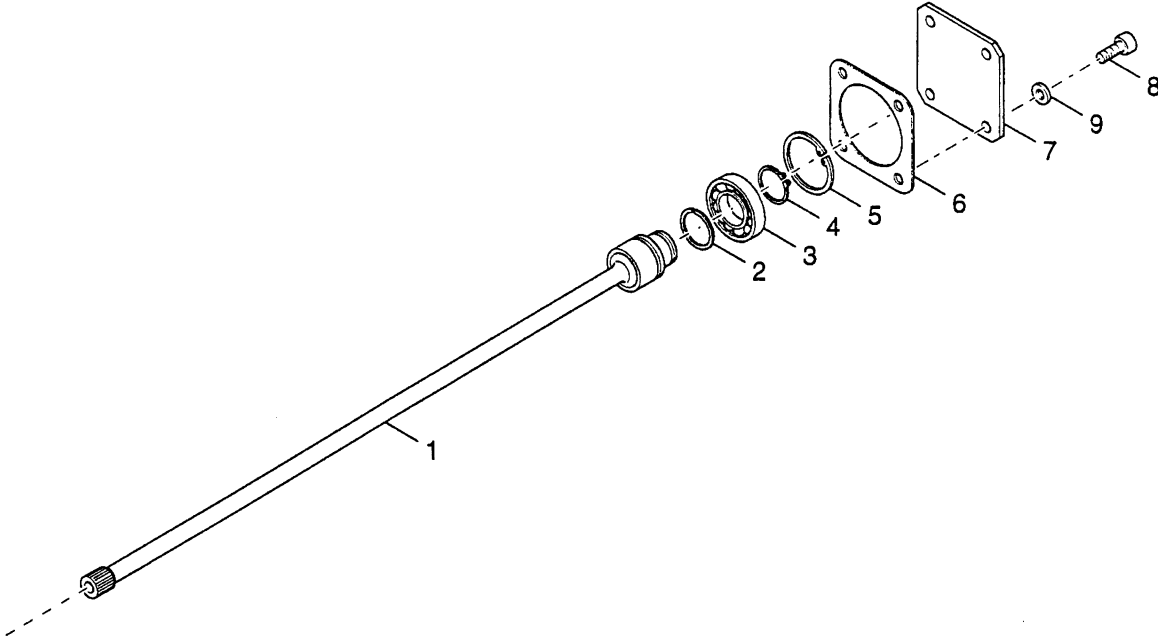

Date : 07-JUL-03
Revised : A
MODEL : 4500703

T16000
GROUP-PUMP DRIVE

<u>Item</u>	<u>Qty</u>	<u>Part Number</u>	<u>%</u>	<u>Description</u>	
1	1	4204235	E	SHAFT PUMP DRIVE	
2	1	4203867	B	RING PISTON	
3	1	230829	C	BEARING-CLUTCH DRIVEN GEAR	
4	1	5JM40	D	SNAPRING	
5	1	7JM68	D	RETAINING-RING	
6	1	4201747	B	GASKET	
7	1	216355	D	COVER-PERMANENT PUMP ADAPTOR	
8				Not Used On This Model	
9	4	4E8		LOCKWASHER	
	4	4204273		SPACER	N.I.
	4	62D8		NUT	N.I.

N.S.S. - Not Sold Separately
N.I. - Not Illustrated
% - Part Stock Recommendation

T16000

CHARGING PUMP GROUP

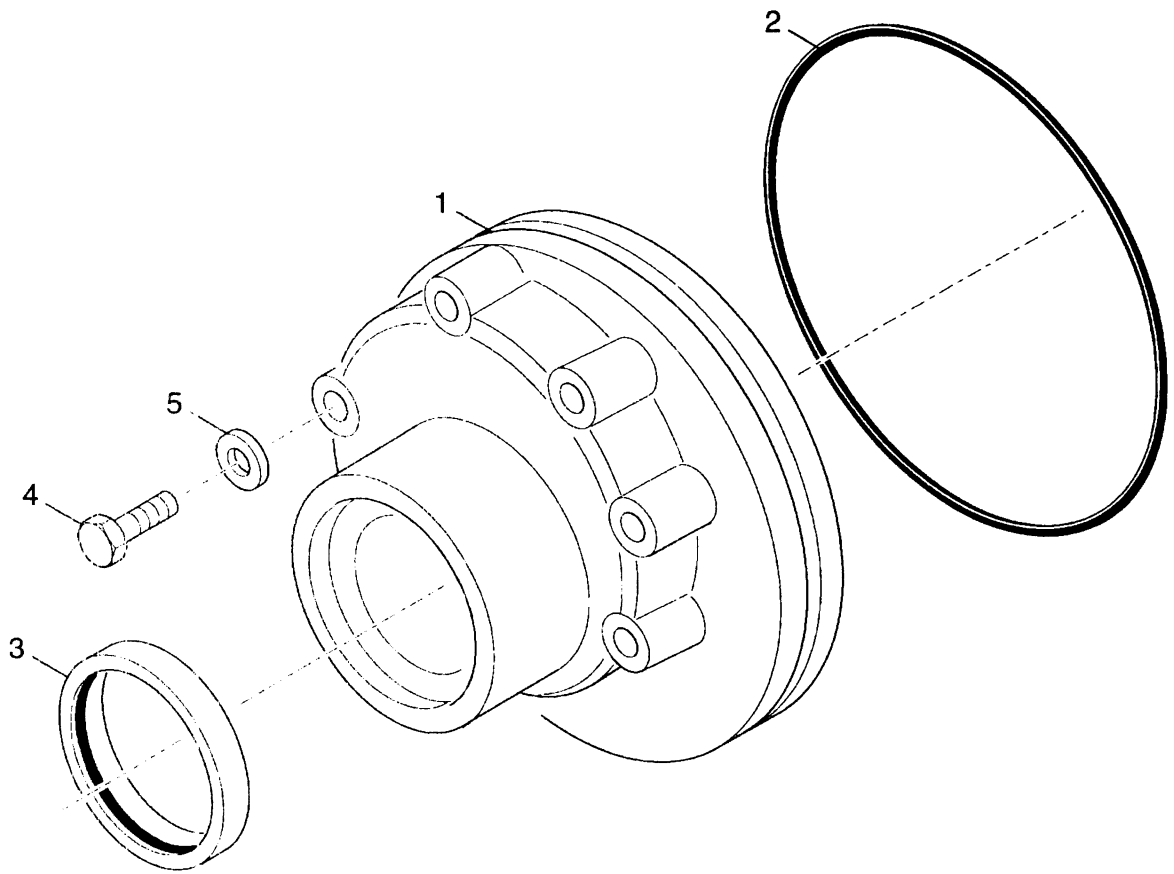

Date : 07-JUL-03
Revised :
MODEL : 4500670

T16000
GROUP-CHARGING PUMP INTERNAL

<u>Item</u>	<u>Qty</u>	<u>Part Number</u>	<u>%</u>	<u>Description</u>
1	1	4203850	D	ASSY-CHARGING PUMP-INCLUDING ITEMS 2 AND 3
2	1	4203844	B	O-RING CHARGING PUMP
3	1	4204279	B	OIL-SEAL
4	6	1CM855		SCREW - PUMP MOUNTING
5	6	4203428	B	WASHER-SEAL

N.S.S. - Not Sold Separately
N.I. - Not Illustrated
% - Part Stock Recommendation

T16000

FWD LOW / FWD HIGH SHAFT AND GEARS GROUP

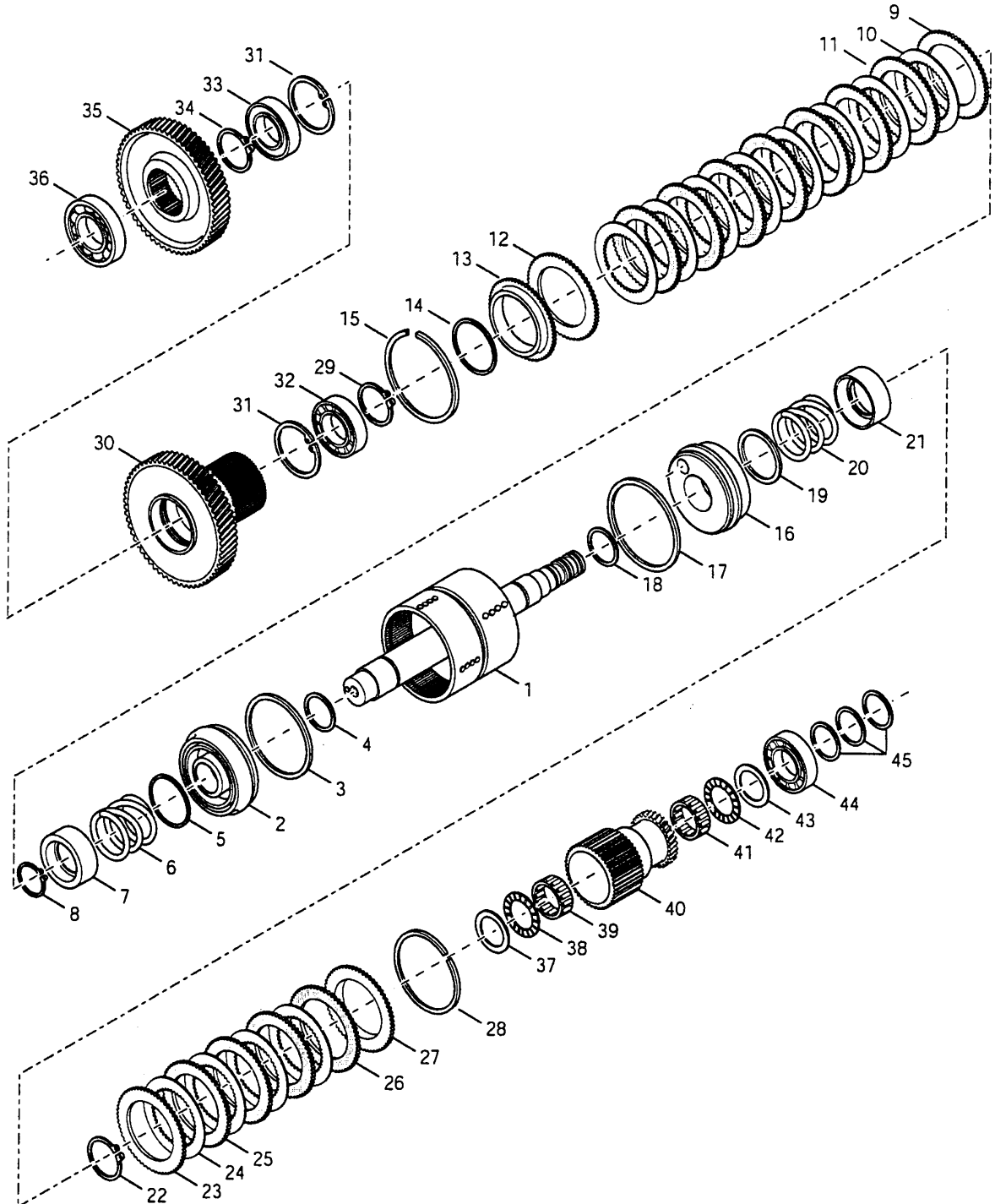

Date : 07-JUL-03
Revised :
MODEL : 4501712

T16000
GROUP-FWD LOW/FWD HIGH SHAFT AND GEARS

<u>Item</u>	<u>Qty</u>	<u>Part Number</u>	<u>%</u>	<u>Description</u>
1	1	4206063	E	ASSY FWD/LOW/HIGH SHAFT,HUB,DRUM,PLUG
2	1	4203742	E	ASSY-CLUTCH PISTON-INCLUDING ITEMS 3 & 4
3	1	237032	B	SEAL-CLUTCH PISTON - OUTER-PART OF ITEM 2
4	1	234113	B	SEAL-CLUTCH PISTON - INNER-PART OF ITEM 2
5	1	4203876	D	SPACER-CLUTCH PISTON SPRING
6	1	4203878	D	RETURN-SPRING
7	1	4203877	D	RETAINER-SPRING
8	1	234350	C	RING-RETAINING
9	1	4204265	C	DISC OUTER HALF (PAPER)
10	8	4204267	C	DISC INNER (TUMBELD BOTH SIDES)
11	7	4204266	C	DISC OUTER (PAPER)
12	1	4204265	C	DISC OUTER HALF (PAPER)
13	1	4206067	D	ASSY-END PLATE & SEAL - INCLUDING ITEM 14
14	1	4206069	B	SEAL LIP - PART OF ITEM 13
15	1	234111	C	SNAP RING
16	1	4203742	E	ASSY-CLUTCH PISTON - INCLUDING ITEMS 17 & 18
17	1	237032	B	SEAL-CLUTCH PISTON - OUTER-PART OF ITEM 16
18	1	234113	B	SEAL-CLUTCH PISTON - INNER-PART OF ITEM 16
19	1	4203876	D	SPACER-CLUTCH PISTON SPRING
20	1	4203878	D	RETURN-SPRING
21	1	4203877	D	RETAINER-SPRING
22	1	234350	C	RING-RETAINING
23	1	4204265	C	DISC OUTER HALF (PAPER)
24	4	4204267	C	DISC INNER (TUMBELD BOTH SIDES)
25	3	4204266	C	DISC OUTER (PAPER)

N.S.S. - Not Sold Separately
N.I. - Not Illustrated
% - Part Stock Recommendation

Date : 07-JUL-03
Revised :
MODEL : 4501712

T16000
GROUP-FWD LOW/FWD HIGH SHAFT AND GEARS

<u>Item</u>	<u>Qty</u>	<u>Part Number</u>	<u>%</u>	<u>Description</u>
26	1	4204265	C	DISC OUTER HALF (PAPER)
27	1	4204253	C	END PLATE
28	1	234111	C	SNAP RING
29	1	5JM50	C	SNAP RING
30	1	4206066	D	GEAR CLUTCH 54T (FREUDENBERG)
31	2	7JM80	D	SNAP RING-INTERNAL
32	1	230885	C	BEARING
33	1	4204256	C	BEARING
34	1	5JM50	C	SNAP RING (FWD/LOW)
35	1	4203980	E	GEAR 42T
36	1	4204257	C	BEARING FRONT 6309 C3
37	1	4203946		WASHER THRUST
38	1	4203947		BEARING THRUST
39	1	4203945		BEARING-NEEDLE
40	1	4203985	E	GEAR CLUTCH 34T FWD HIGH
41	1	4203945		BEARING-NEEDLE
42	1	4203947		BEARING THRUST
43	1	4203946		WASHER THRUST
44	1	237972	C	BEARING 6208 C3
45	3	4203872	B	RING-PISTON

N.S.S. - Not Sold Separately
N.I. - Not Illustrated
% - Part Stock Recommendation

T16000

REVERSE / 1ST SHAFT AND GEARS GROUP

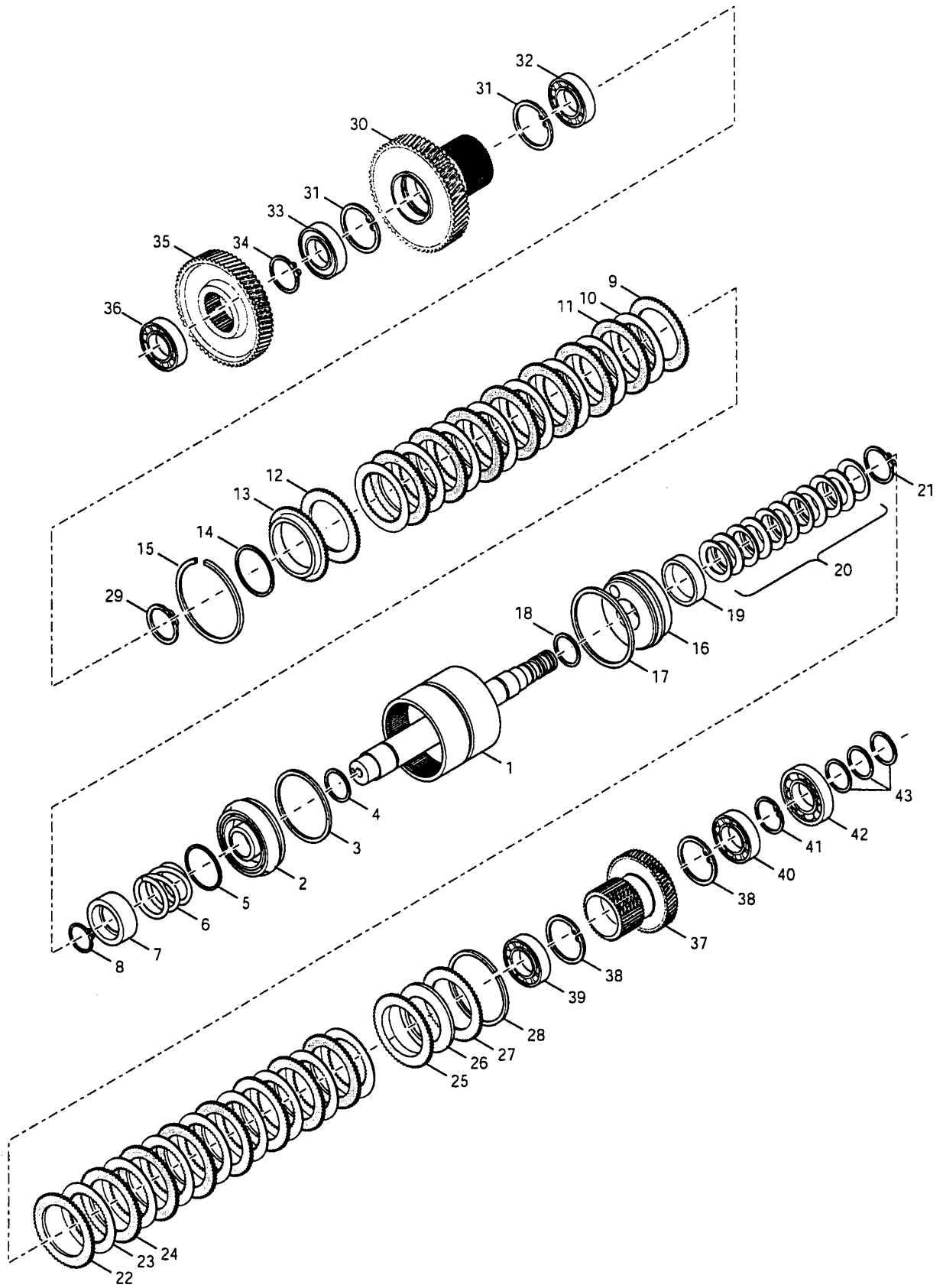

Date : 07-JUL-03
Revised : A
MODEL : 4501713

T16000
GROUP-REVERSE/1ST SHAFT AND GEARS

<u>Item</u>	<u>Qty</u>	<u>Part Number</u>	<u>%</u>	<u>Description</u>
1	1	4207078	E	ASSY REV/1ST SHAFT,HUB,DRUM,PLUG
2	1	4203742	E	ASSY-CLUTCH PISTON - INCLUDING ITEMS 3 & 4
3	1	237032	B	SEAL-CLUTCH PISTON - OUTER
4	1	234113	B	SEAL-CLUTCH PISTON - INNER
5	1	4203876	D	SPACER-CLUTCH PISTON SPRING
6	1	4203878	D	RETURN-SPRING
7	1	4203877	D	RETAINER-SPRING
8	1	234350	C	RING-RETAINING
9	1	4204265	C	DISC OUTER HALF (PAPER)
10	8	4204267	C	DISC INNER (TUMBELD BOTH SIDES)
11	7	4204266	C	DISC OUTER (PAPER)
12	1	4204265	C	DISC OUTER HALF (PAPER)
13	1	4206067	D	ASSY-END PLATE & SEAL - INCL. ITEM 14
14	1	4206069	B	SEAL LIP - PART OF ITEM 13
15	1	234111	C	SNAP RING
16	1	4203742	E	ASSY-CLUTCH PISTON - INCL.ITEMS 17 & 18
17	1	237032	B	SEAL-CLUTCH PISTON - OUTER-PART OF ITEM 16
18	1	234113	B	SEAL-CLUTCH PISTON - INNER-PART OF ITEM 16
19	1	4204300		PISTON CLUTCH SPACER
20	1	4203887		ASSY-SPRING DISC - INCLUDING 11 WASHERS
21	1	234350	C	RING-RETAINING
22	1	4204265	C	DISC OUTER HALF (PAPER)
23	8	4204267	C	DISC INNER (TUMBELD BOTH SIDES)
24	7	4204266	C	DISC OUTER (PAPER)
25	1	4204265	C	DISC OUTER HALF (PAPER)

N.S.S. - Not Sold Separately
N.I. - Not Illustrated
% - Part Stock Recommendation

Date : 07-JUL-03
Revised : A
MODEL : 4501713

T16000
GROUP-REVERSE/1ST SHAFT AND GEARS

<u>Item</u>	<u>Qty</u>	<u>Part Number</u>	<u>%</u>	<u>Description</u>
26	1	4203880	D	SPRING-DISC MODULATOR
27	1	4204253	C	END PLATE
28	1	234111	C	SNAP RING
29	1	5JM50	C	SNAP RING
30	1	4206066	D	GEAR CLUTCH 54T (FREUDENBERG)
31	2	7JM80	D	SNAP RING-INTERNAL
32	1	232885	E	CLUTCH DRUN HUB GEAR (47T)
33	1	4204256	C	BEARING
34	1	5JM50	C	SNAP RING
35	1	4203981	E	GEAR 50T
36	1	4204257	C	BEARING FRONT 6309 C3
37	1	4203986	D	GEAR CLUTCH 30T
38	2	7JM75	C	SNAP RING-INTERNAL
39	1	230860	C	BALL BEARING
40	1	233390	C	BEARING
41	1	5JM45	C	SNAP RING
42	1	4204314	D	BEARING
43	3	4203872	B	RING-PISTON

N.S.S. - Not Sold Separately
N.I. - Not Illustrated
% - Part Stock Recommendation

T16000

INPUT SHAFT GROUP

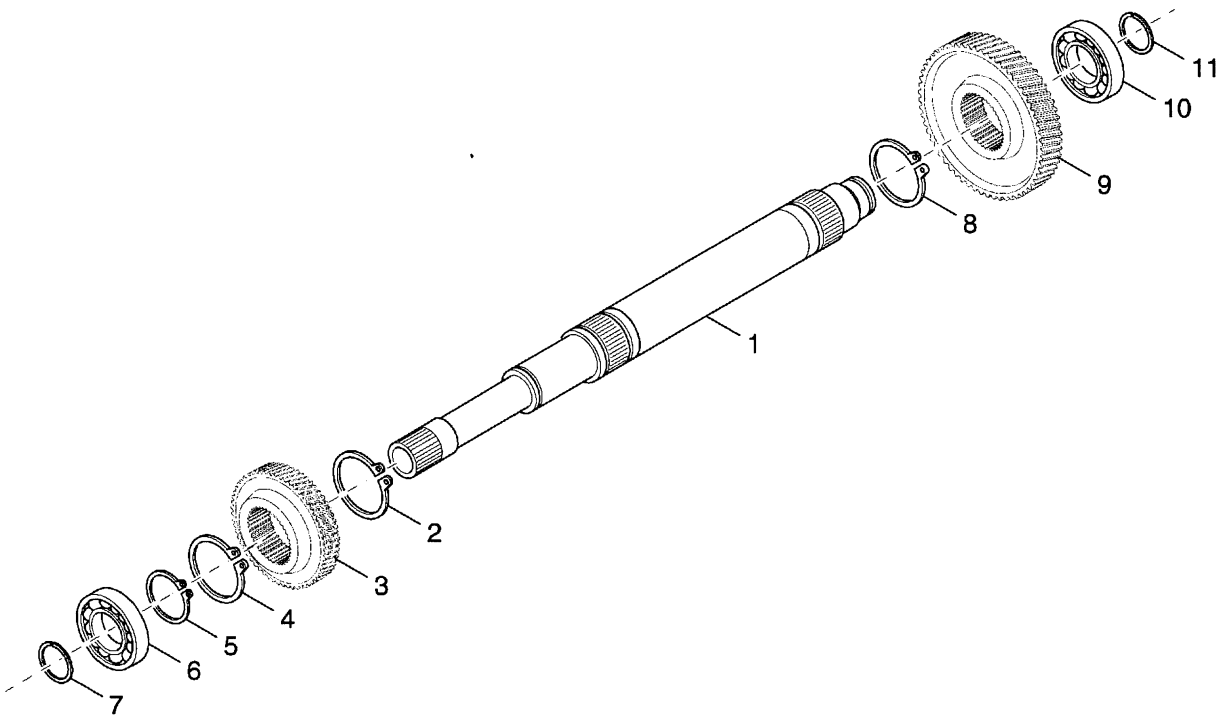

Date : 07-JUL-03
Revised :
MODEL : 4500695

T16000
GROUP-INPUT SHAFT

<u>Item</u>	<u>Qty</u>	<u>Part Number</u>	<u>%</u>	<u>Description</u>
1	1	4204232	E	SHAFT TURBINE
2	1	4204251	D	SNAP RING
3	1	4203978	E	GEAR FWD LOW 26T
4	1	5JM50	C	SNAP RING
5	1	5JM40	D	SNAP RING
6	1	4204314	D	BEARING
7	1	4203872	B	RING-PISTON
8	1	5JM50	C	SNAP RING
9	1	4203977	E	GEAR 62T
10	1	4204314	D	BEARING
11	1	4203872	B	RING-PISTON

N.S.S. - Not Sold Separately
N.I. - Not Illustrated
% - Part Stock Recommendation

T16000

2ND SHAFT GROUP

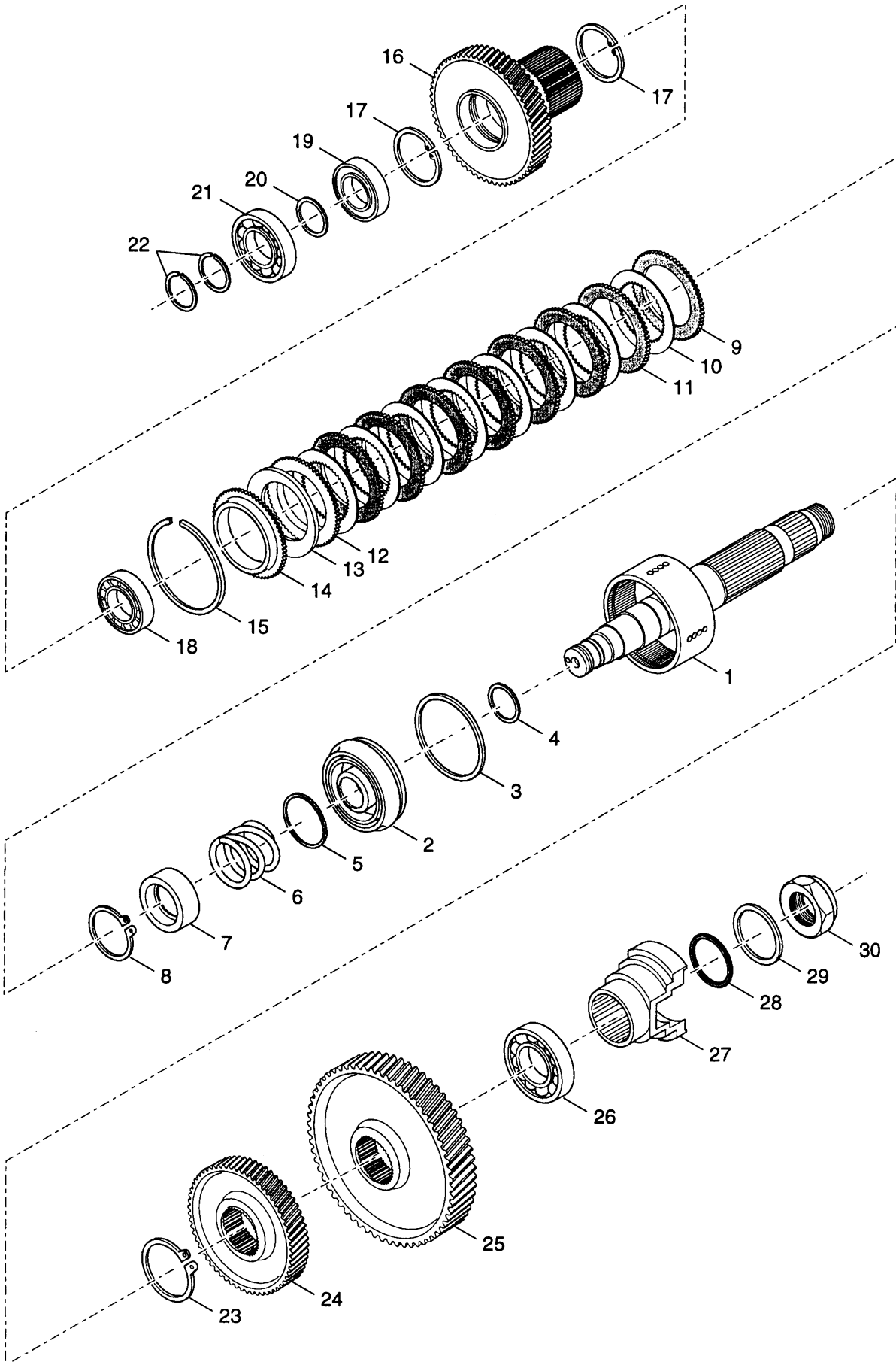

Date : 07-JUL-03
Revised :
MODEL : 4500716

T16000
GROUP-2ND SHAFT

<u>Item</u>	<u>Qty</u>	<u>Part Number</u>	<u>%</u>	<u>Description</u>
1	1	4204307	E	ASSY 2ND SHAFT, HUB, DRUM AND PLUG
2	1	4203742	E	ASSY-CLUTCH PISTON - INCLUDING ITEMS 3 & 4
3	1	237032	B	SEAL-CLUTCH PISTON - OUTER - PART OF ITEM 2
3	1	234113	B	SEAL-CLUTCH PISTON - INNER - PART OF ITEM 2
5	1	4203876	D	SPACER-CLUTCH PISTON SPRING
6	1	4203878	D	RETURN-SPRING
7	1	4203877	D	RETAINER-SPRING
8	1	234350	C	RING-RETAINING
9	1	4204265	C	DISC OUTER HALF (PAPER)
10	8	4204267	C	DISC INNER (TUMBELD BOTH SIDES)
11	7	4204266	C	DISC OUTER (PAPER)
12	1	4204265	C	DISC OUTER HALF (PAPER)
13	1	4203880	D	SPRING-DISC MODULATOR
14	1	4204253	C	END PLATE
15	1	234111	C	SNAP RING
16	1	4203984	E	GEAR CLUTCH 52T
17	2	7JM75	C	SNAP RING-INTERNAL
18	1	230860	C	BALL BEARING
19	1	233390	C	BEARING
20	1	4203899		WASHER-BEARING SUPPORT
21	1	4204314	D	BEARING
22	2	4203872	B	RING-PISTON
23	1	249936	C	SNAP RING-EXTERNAL
24	1	4203979		GEAR 41T
25	1	4203982	E	GEAR UPPER OUTPUT 59T

N.S.S. - Not Sold Separately
N.I. - Not Illustrated
% - Part Stock Recommendation

Date : 07-JUL-03
Revised :
MODEL : 4500716

T16000
GROUP-2ND SHAFT

<u>Item</u>	<u>Qty</u>	<u>Part Number</u>	<u>%</u>	<u>Description</u>
26	1	4204258	C	BEARING 6311 C3
27	1	4203852	E	FLANGE-YOKE 1410 WITHOUT BRAKE
28	1	25K60128	B	"O" RING
29	1	231916	D	WASHER
30	1	215634	C	NUT-IDLER SHAFT

N.S.S. - Not Sold Separately
N.I. - Not Illustrated
% - Part Stock Recommendation

T16000

OUTPUT SHAFT WITH INTERNAL DISCONNECT GROUP

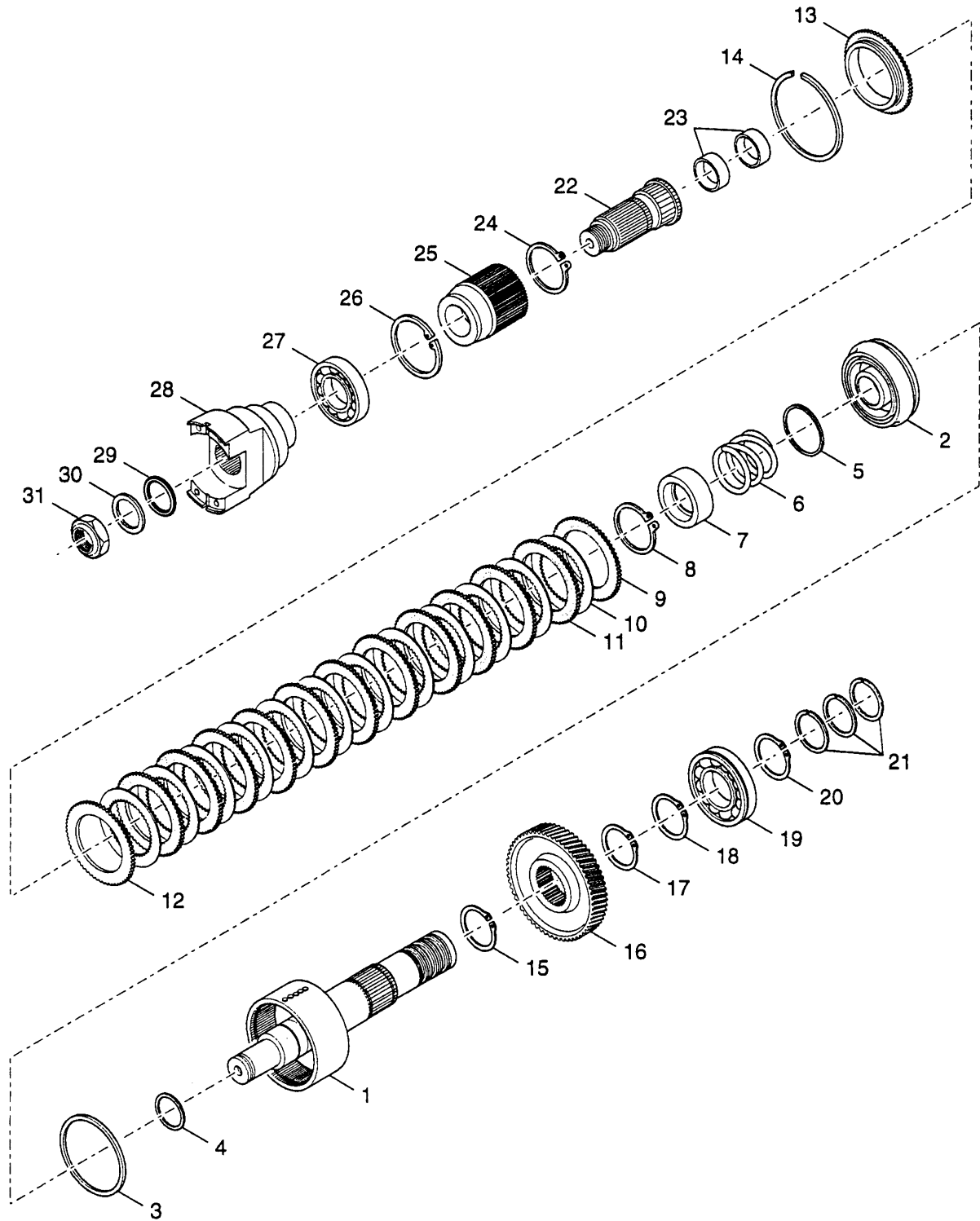

Date : 07-JUL-03
Revised : C
MODEL : 4500717

T16000
GROUP-OUTPUT SHAFT

<u>Item</u>	<u>Qty</u>	<u>Part Number</u>	<u>%</u>	<u>Description</u>
1	1	4206718	E	ASSY OUTPUT SHAFT,HUB,DRUM W/O FLANGE
2	1	4203742	E	ASSY-CLUTCH PISTON - INCL.ITEMS 3 & 4
3	1	237032	B	SEAL-CLUTCH PISTON - OUTER - PART OF ITEM 2
4	1	234113	B	SEAL-CLUTCH PISTON - INNER - PART OF ITEM 2
5	1	4203876	D	SPACER-CLUTCH PISTON SPRING
6	1	4203878	D	RETURN-SPRING
7	1	4203877	D	RETAINER-SPRING
8	1	234350	C	RING-RETAINING
9	1	4204265	C	DISC OUTER HALF (PAPER)
10	12	4204267	C	DISC INNER (TUMBELD BOTH SIDES)
11	11	4204266	C	DISC OUTER (PAPER)
12	1	4204265	C	DISC OUTER HALF (PAPER)
13	1	4204253	C	END PLATE
14	1	234111	C	SNAP RING
15	1	5JM65	C	SNAPRING GEAR RETAINER
16	1	4203983	D	GEAR LOWER OUTPUT 39T
17	1	5JM65	C	SNAPRING GEAR RETAINER
18	1	5JM60	D	SNAPRING GEAR RETAINER
19	1	4204260	D	BEARING
20	1	5JM60	D	SNAPRING GEAR RETAINER
21	3	4203898	B	RING-PISTON
22	1	4204261	E	ASSY OUTPUT SHAFT FRONT - INCL.ITEM 23
23	2	4205018	C	BUSHING-DISCONNECT - PART OF ITEM 22
24	1	249936	C	SNAP RING-EXTERNAL
25	1	4203988		HUB DISCONNECT

N.S.S. - Not Sold Separately
N.I. - Not Illustrated
% - Part Stock Recommendation

Date : 07-JUL-03
Revised : C
MODEL : 4500717

T16000
GROUP-OUTPUT SHAFT

<u>Item</u>	<u>Qty</u>	<u>Part Number</u>	<u>%</u>	<u>Description</u>
26	1	7JM100	D	SNAP-RING
27	1	225874	D	REAR BEARING
28	1	4203852	E	FLANGE-YOKE 1410 WITHOUT BRAKE
29	1	25K60128	B	O RING
30	1	231916	D	WASHER
31	1	215634	C	NUT-IDLER SHAFT

N.S.S. - Not Sold Separately
N.I. - Not Illustrated
% - Part Stock Recommendation

T16000

CONTROL VALVE MOUNTING GROUP

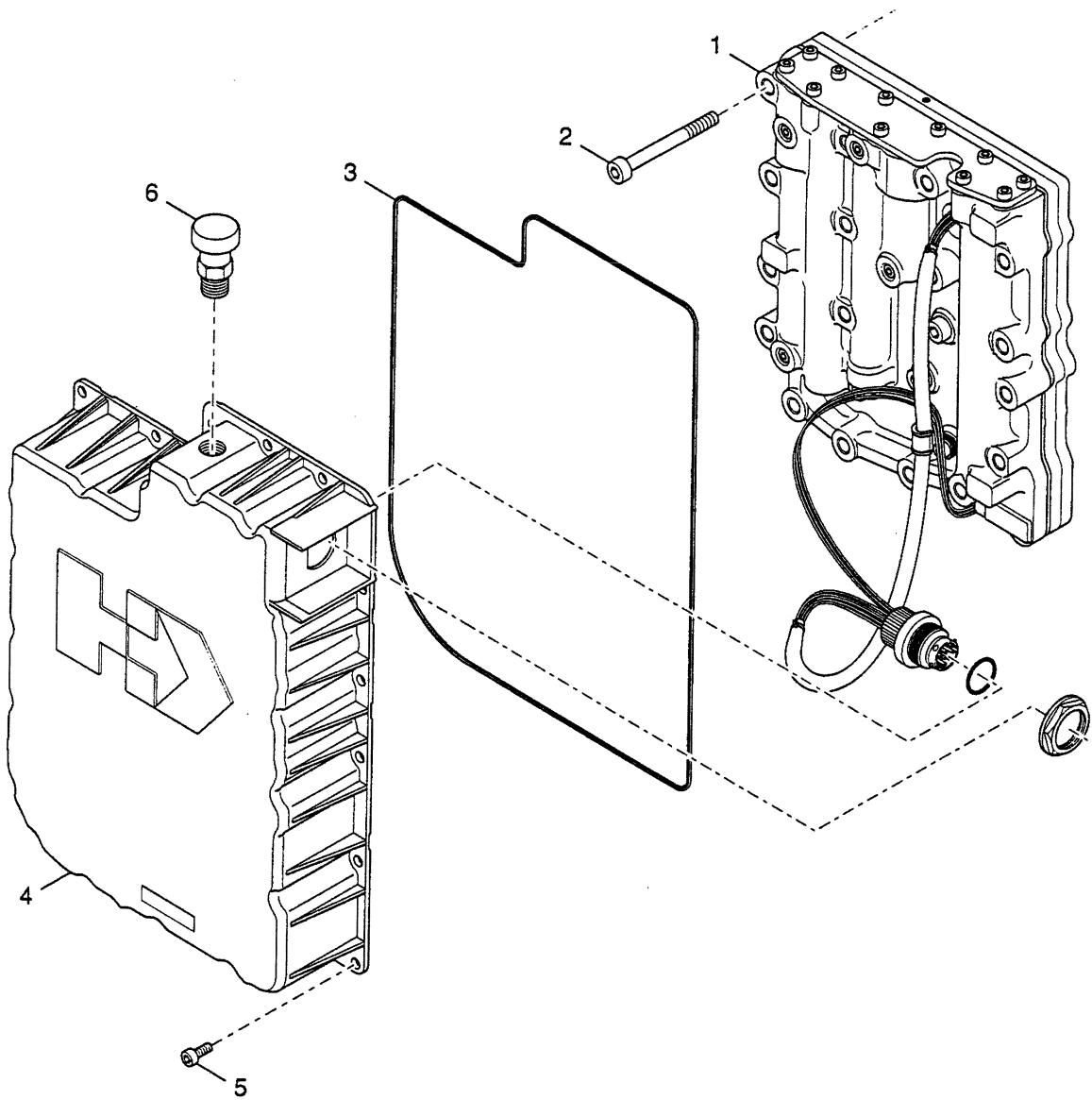

Date : 07-JUL-03
Revised : A
MODEL : 4501579

T16000
GROUP-CONTROL VALVE

<u>Item</u>	<u>Qty</u>	<u>Part Number</u>	<u>%</u>	<u>Description</u>
1	1	4205806	E	ASSY CONTROL VALVE
2	17	1GM865		SCREW (DIN 912)
3	1	4203922	B	SEAL COVER VALVE
4	1	4204264		ASSY-PROTECTION COVER & BREATHER-INCL.ITEM 6
5	9	1GM612		SCREW M6
6	1	238535	C	AIR-BREATHER - PART OF ITEM 4

N.S.S. - Not Sold Separately
N.I. - Not Illustrated
% - Part Stock Recommendation

T16000

CONTROL VALVE ASSEMBLY

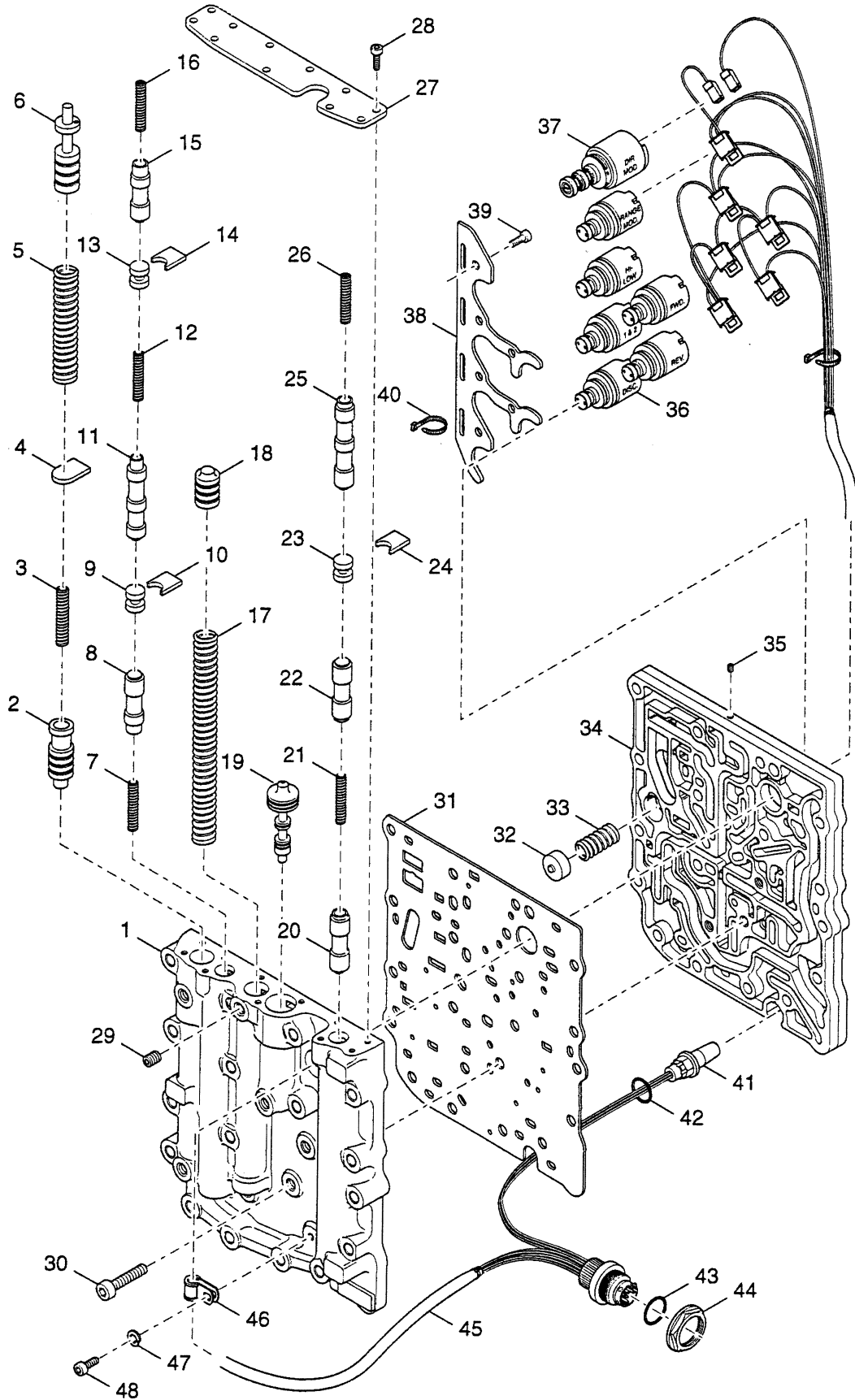

Date : 03-JUN-08
Revised :
MODEL : 4205806

T16000
ASSY CONTROL VALVE

<u>Item</u>	<u>Qty</u>	<u>Part Number</u>	<u>%</u>	<u>Description</u>
1	1	N.S.S.		SPOOL BODY
2	1	N.S.S.		PRESSURE REDUCER SPOOL
3	1	N.S.S.		PRESSURE REDUCER SPRING
4	1	N.S.S.		SEPARATOR PLATE
5	1	N.S.S.		PRESSURE REGULATOR SPRING
6	1	N.S.S.		PRESSURE REGULATOR SPOOL
7	1	N.S.S.		PILOT SPOOL SPRING
8	1	N.S.S.		DISCONNECT SPOOL
9	1	N.S.S.		SPOOL STOP
10	1	N.S.S.		SEPARATOR PLATE
11	1	N.S.S.		1ST/2ND SPOOL
12	1	N.S.S.		PILOT SPOOL SPRING
13	1	N.S.S.		SPOOL STOP
14	1	N.S.S.		SEPARATOR PLATE
15	1	N.S.S.		RANGE MODULATION SPOOL
16	1	N.S.S.		PILOT SPOOL SPRING
17	1	N.S.S.		ACCUMULATOR SPRING
18	1	N.S.S.		ACCUMULATOR SPOOL
19	1	N.S.S.		BOOSTER SPOOL
20	1	N.S.S.		REVERSE SPOOL
21	1	N.S.S.		PILOT SPOOL SPRING
22	1	N.S.S.		FORWARD SPOOL
23	1	N.S.S.		SPOOL STOP
24	1	N.S.S.		SEPARATOR PLATE
25	1	N.S.S.		FWD LOW / FWD HIGH SPOOL

N.S.S. - Not Sold Separately
N.I. - Not Illustrated
% - Part Stock Recommendation

Date : 03-JUN-08
Revised :
MODEL : 4205806

T16000
ASSY CONTROL VALVE

<u>Item</u>	<u>Qty</u>	<u>Part Number</u>	<u>%</u>	<u>Description</u>
26	1	N.S.S.		PILOT SPOOL SPRING
27	1	N.S.S.		SPOOL COVER
28	11	1GM512		SCREW M5
29	3	16F2		PIPE PLUG
30	3	1GM830		CAPSCREW
31	1	N.S.S.		PLATE-SPACER
32	1	4203943		SPOOL-BYPASS VALVE
33	1	4203944		SPRING-BYPASS VALVE
34	1	N.S.S.		PLATE-SOLENOIDS
35	6	4203975		SCREW
36	6	4205795	C	SOLENOID 12V
37	1	4203146	C	VFS SOLENOID
38	1	N.S.S.		SOLENOID CLAMP
39	6	1GM512		SCREW M5
40	6	4202198		STRAP 2,4 X 200 MM
41	1	N.S.S.		SENSOR-SPEED & TEMP
42	1	N.S.S.		O RING
43	1	N.S.S.		O RING
44				Not Used On This Model
45	1	4212419	D	ASSY-WIRING HARNESS - INCL.ITEMS 41,42 AND 43
46	1	4203974		CLAMP WIRING
47	1	1EM50		LOCKWASHER
48	1	1GM510		CAPSCREW M5X10

N.S.S. - Not Sold Separately
N.I. - Not Illustrated
% - Part Stock Recommendation

T16000

DRIVE PLATE GROUP

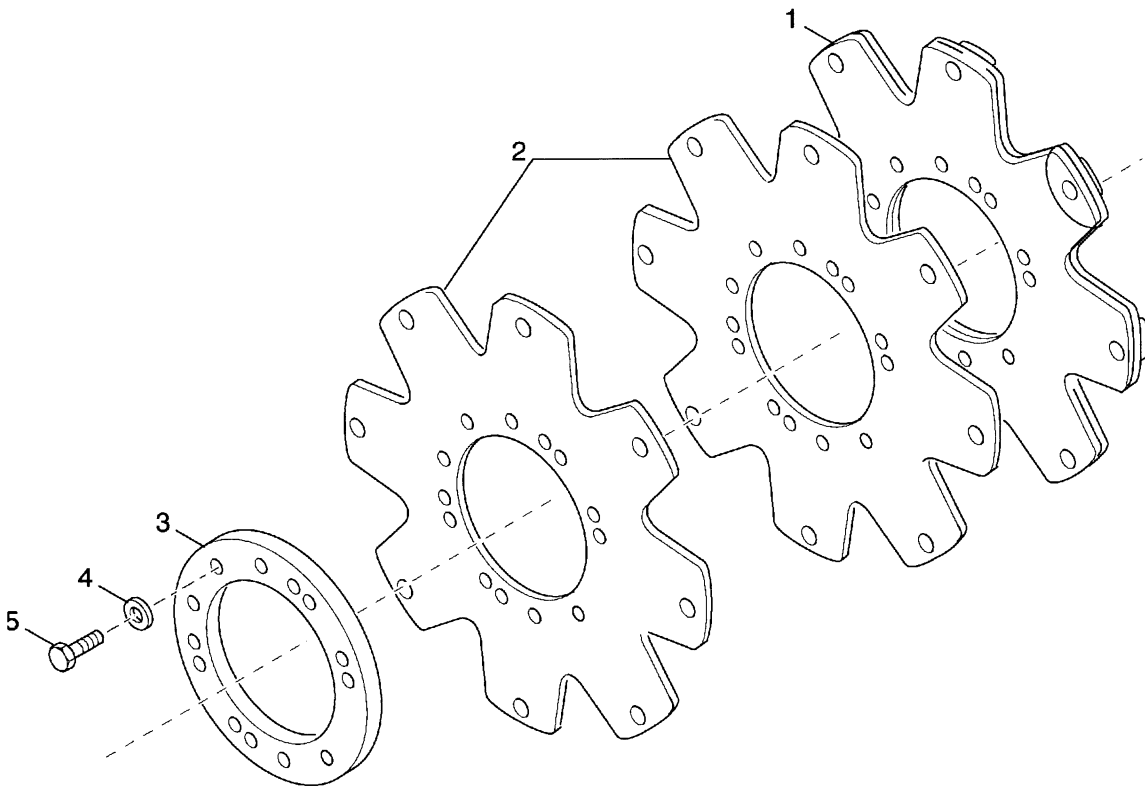

GRPT16111

Date : 07-JUL-03
Revised :
MODEL : 4502993

T16000
GROUP-DRIVE PLATE

<u>Item</u>	<u>Qty</u>	<u>Part Number</u>	<u>%</u>	<u>Description</u>
1	1	N.S.S.		ASSY-DRIVE PLATE - INCLUDING IN ITEM 6
2	2	N.S.S.		PLATE-DRIVE - INCLUDING IN ITEM 6
3	1	246615	B	RING-BACKING
4	6	4E6		LOCKWASHER-DRIVE PLATE MTG SCREW
5	6	2C608		CAPSCREW
6	1	8100084	D	T16000 DRIVE PLATE KIT-INCL. ITEM 1 THRU 5

N.S.S. - Not Sold Separately
N.I. - Not Illustrated
% - Part Stock Recommendation

T16000

PARKING BRAKE GROUP

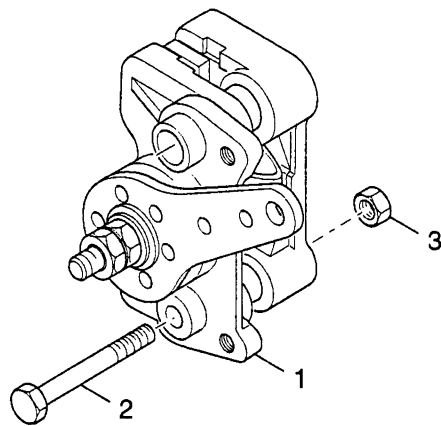

Date : 07-JUL-03
Revised : A
MODEL : 4500676

T16000
GROUP-PARKING BRAKE

<u>Item</u>	<u>Qty</u>	<u>Part Number</u>	<u>%</u>	<u>Description</u>
1	1	4205399	A	ASSY-CALIPER
2	2	17C872		CAPSCREW
3	2	63D8		NUT

N.S.S. - Not Sold Separately
N.I. - Not Illustrated
% - Part Stock Recommendation

Model: 16000

KIT-GASKET AND SEALING

QTY SHOWN IS TO MAKE ONE OF THE NEXT HIGHER ASSEMBLY

REV	P	PART NUMBER	QTY	S/E	PARTNAME AND APPLICATION
		76K119	1		O RING
		76K123	1		O-RING
		76K11	2		O RING
		76K116	11		O-RING
		4204245	1		O-RING FILTER ADAPTER
		25K30228	1		O-RING
		76K218	1		O RING
		4203901	1		GASKET-CONV HSG TO TRANS CASE
		60K20028	2		O RING
		76K13	2		O RING
		4203860	2		OIL SEAL
		76K210	1		O RING
		219373	1		GASKET
		60K40212	1		O RING
		4203867	1		RING PISTON
		4201747	1		GASKET
		4203844	1		O-RING CHARGING PUMP
		4204279	1		OIL-SEAL
		237032	6		SEAL-CLUTCH PISTON - OUTER
		234113	6		SEAL-CLUTCH PISTON - INNER
		4204255	2		PISTON RING
		4203872	10		RING-PISTON
		4203898	3		RING-PISTON
		25K60128	2		O RING
		4203922	1		SEAL COVER VALVE
		60K30022	1		O RING
		60K40030	1		O RING

Ltr :
Date:
ECN :

Issued : sv

Rel : sv
Date: 16-FEB-01
ERN : SERV



Part Stocking Recommendation

The table below is a minimum spare parts inventory recommendation designated by letter code in each Service Parts List. Each letter code indicates a percentage for determining stock quantities to support the field population. Any quantity less than 1 or partial quantities need not be stocked.

Letter Code	Percentage	Example
A	15%	Part quantity = 10 per unit Field Population = 240 units Recommended stock = 240 units x 10 per unit x .15 = 360 parts
B	10%	Part quantity = 4 per unit Field Population = 66 units Recommended stock = 66 units x 4 per unit x .10 = 26.4 or 26 parts
C	6%	Part quantity = 2 per unit Field Population = 203 units Recommended stock = 203 units x 2 per unit x .06 = 24.4 or 24 parts
D	4%	Part quantity = AR* Field Population = 42 units Recommended stock = 42 units x 3 per unit x .04 = 5.04 or 5 parts
E	2%	Part quantity = 1 per unit Field Population = 75 units Recommended stock = 75 units x 1 per unit x .02 = 1.5 or 1 part

*Part quantities denoted by "AR" (as required) should be ordered by a quantity of 3 per unit.

© Copyright 2014 Dana Holding Corporation
All content is subject to copyright by Dana and may not
be reproduced in whole or in part by any means,
electronic or otherwise, without prior written approval.
THIS INFORMATION IS NOT INTENDED FOR SALE OR
RESALE, AND THIS NOTICE MUST REMAIN ON ALL
COPIES.

For product inquiries or support,
visit www.dana.com or call 419-887-6445
For other service publications,
visit www.SpicerParts.com/literature.asp
For online service parts ordering,
visit www.SpicerParts.com/order.asp



SPICER[®]

Off-Highway Products